

CAD FILE:

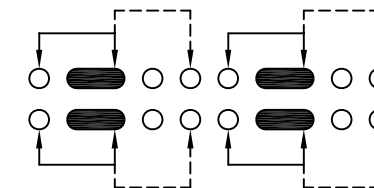

SCHEMATIC (NOT-SPECIFIED)

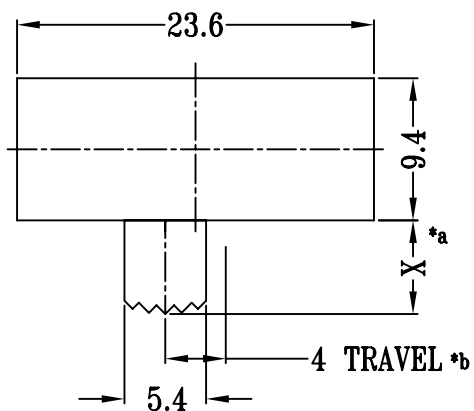
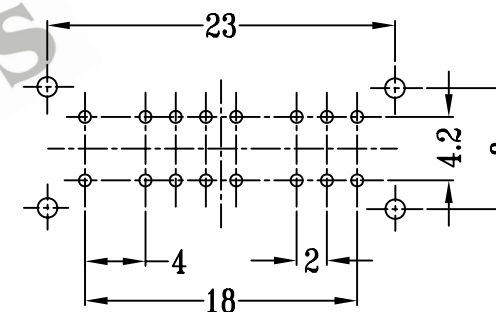
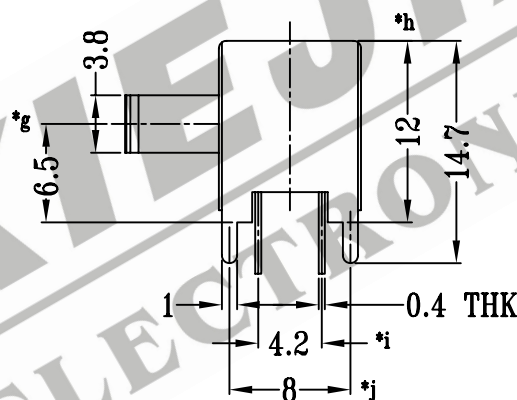
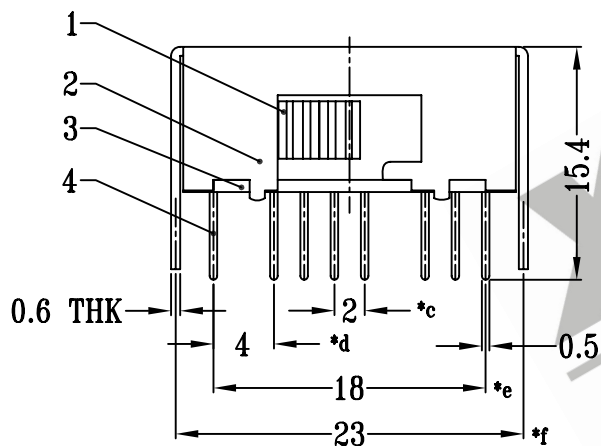

P.C.B LAYOUT

注：“*”表示关键尺寸（10个）

NO.	PART NAME	MATERIAL	Q'TY	FINISHING	TOLERANCE UNLESS SPECIFIED	SHENZHEN XIEJIA ELECTRONICS CO.,LTD.				
8						ISSUE	DATE	DESCRIPTIONS		APPD.
7	STEEL BALL	STEEL	1	NATURAL	WITHIN: 1.5±0.1mm					
6	SPRING	STEEL WIRE	1	TEMPER	OVER : 1.5±0.2mm	MODEL: SK-42H01		SCALE: 2:1	DWN. ZHOUYU	2003-9-8
5	CONTACT CLIP	PBS STRIP	4	Ag PLATED					CHK'D FANGYING	2003-9-8
4	TERMINAL	BRASS STRIP	16	Ag PLATED OVER Ni PLATED		ALL MATERIALS MUST BE COMPLIANT TO ROHS			APPD. KANGXINAN	2003-9-8
3	BASE	PHENOLIC RESIN	1	NATURAL						
2	FRAME	STEEL STRIP	1	Ni PLATED						
1	KNOB	POM	1	BLACK						